

Ecovector® HL



Installation, commissioning
and user manual



HL1000 | HL1000-12V
HL2300 | HL2900 | HL4000

High Level Fan Convector

Contents

Introduction	2
Declaration of conformity	3
Symbols used in this guide	3
Important safety and installation instructions	4
Product dimensions	6
Product performance	6
Installation	8
Electrical connection	8
Commissioning	9
Fault finding	10
User Manual	10
Heating	10
Registering your product	11
Disposal	11
After sales	11

Introduction

In the event of items missing or visible damage please contact us on 01245 324560.

The following items should be included in the carton:

- Product complete with cable
- Transformer (HL 1000-12V only)

This heater is primarily intended for installation onto a wall at high level. The maximum recommended installation height is 2.1 metres to the underside of the heater. There is no clearance required above or to the side of the heater.

Electrical installations for these heaters must only be carried out by a suitably qualified person.

Model HL 1000-12V

This model is designed for use in bathrooms and other high humidity areas. For these applications it is essential that the heater, transformer and fused spur are installed in line with current regulations relative to fixed current equipment in high humidity areas, wet rooms and/or bath and shower rooms.

The transformer has been designed to fit into a surface-mounted or recessed pattress box (not supplied) similar to those used for shaver sockets (47mm deep). The transformer can be mounted

horizontally or vertically however it must not be directly above the heater but should be accessible after completion of the installation.

Supply to the transformer must be via a 3 amp fused spur. The fused spur must not be directly above the heater but should be accessible after completion of the installation. Twin core cable is fitted to the product for connection to transformer. HL 1000-12V should not be earthed.

Models HL 1000, HL 2300, HL 2900 & HL 4000

These models must not be installed in bathrooms or other high humidity areas.

Ecovector is classified as a fixed appliance and electrical connection should be via a 3A-fused spur. The fused spur must not be directly above the heater but should be accessible after completion of the installation. If the pre-wired mains cable is damaged it must be replaced by the manufacturer, its service agent or similarly qualified persons. This appliance must be earthed.

For models HL 2900 and HL 4000 we recommended that when securing the product to the wall two persons should lift the heater into position.

All models

These heaters are designed for use on standard two-pipe pumped central heating systems. Pipes are 15mm for models HL 1000, HL 1000-12V, HL 2300, HL 2900 and 22mm for model HL 4000. Either pipe may be used as flow or return. These heaters are not suitable for one-pipe systems.

We recommend the use of full flow isolating valves. The valves should be accessible after completion of the installation. We also advise the fitting of an air vent at the highest point on either the flow or return pipe to remove any air trapped within the system.

To avoid the possibility of vibration these heaters must be fitted on a flat even surface.

To conform to Building Regulations Part L (Part J in Scotland) these Ecovector heaters can be controlled by a remote wall mounted room thermostat (Smith's Environmental Products Part No. RT002). For further details please contact us on 01245 324560.

Declaration of conformity

EC Declaration of conformity

We, Smith's Environmental Products Limited
1-2 Blackall Industrial Estate
South Woodham Ferrers
Chelmsford
Essex CM3 5UW
Tel: 01245 324900 Fax: 01245 324422

Declare under sole responsibility that the products:

Product name:
Ecovector High Level

Product range:
HL1000, HL2300, HL2900, HL4000, HL1000-12V

Listed above conforms with the following directives:

Low Voltage Directive 2006/95/EC / Electrical Equipment (Safety) Regulations 2016
EMC Directive 2004/108/EC / Electromagnetic compatibility Regulations 2016
Pressure Equipment directive 97/23/EC / Pressure Equipment (Safety) Regulations 2016
Machinery Directive 98/37/EC / Supply of Machinery (Safety) Regulations 2008

Safety Directive Standards:

EN 60335-2-80:2003 + A1:04 in conjunction with EN 60335-1:2002 + A11:04 + A1:04 + A12:06 + A2:06
With U.K deviations.

EMC Directive Standards:

EN 55014-1:2000+A1:01+A2:02
EN 61000-3-2:2000
EN 61000-3-3:1995+A1:01+A2:05

EMF Standards:

EN 50366:2003+A1:06

This Declaration is made on behalf of Smith's Environmental Products Limited.

Symbols

This manual contains information and prescriptions marked by the following symbols.



Ignoring these safety provisions marked by the symbol "caution: hazard" may endanger the safety of people.



Ignoring these safety provisions marked by the symbol "caution: electricity" may endanger the safety of people, as well as the integrity of things.



The removal of the screws can cause the output of hot fluids under high pressure from heating system. Drain the system or close the isolating valves.



High temperature surface. Take utmost care to prevent people from getting in contact with the hot surfaces of the appliance.

Important safety and installation instructions

Prior to installation, read these installation and operating instructions. The installation and operation should also be in accordance with national regulations and accepted codes of good practice.



This appliance is not intended for use by persons (including children) with reduced physical, sensory or mental capabilities, or lack of experience and knowledge, unless they have been given supervision or instruction concerning use of the appliance by a person responsible for their safety. Children should be supervised to ensure that they do not play with the appliance.

To guard against injury, basic safety precautions should be observed, including the following:

1. Read and follow all safety instructions and all the important notices on the appliance before installing, using and maintaining the appliance. Failure to do so may cause personal injury or damage to the appliance or installation.
2. Always disconnect electrical supply before putting on or taking off parts and whilst the equipment is being installed, maintained or handled. Never work with bare feet and/or with wet hands.
3. To avoid possible electric shock, special care should be taken since water is used with electrical equipment. Carefully examine the appliance before and after installation. Do not operate the appliance if it has a damaged supply cord or enclosure, or if it is malfunctioning or it is dropped or damaged in any manner. Inspect the appliance periodically.



The appliance should not be electrically supplied if there is water on parts not intended to be wet.

4. Risk of scalding. To avoid injury before any servicing operation wait until the water has cooled inside the appliance. Do not touch the fluid or the appliance when temperature is higher than 60°C.



5. Improper use.

This is an appliance to be used in heating systems with clean water without abrasive particles.



Do not use this appliance:

- With liquids other than water (e.g. flammable liquids, etc.) (EN60335-2-51);
- In locations where special conditions prevail, such as the presence of a corrosive or explosive atmosphere (dust, vapour or gas) (EN60335-2-51);
- For other than intended use.

6. Installation.

The appliance must be mounted in a stable/fixed position in a dry, well ventilated, frost-free, waterproof and protected place, with sufficient ventilation around it. Make sure that the appliance is securely and correctly installed before operating it and that there is enough room around it for maintenance operations, dismantling, checking for free inspection.

The maximum ambient temperature at which the appliance is to be used is 40°C (EN60335-2-51).



7. Electric connection

IMPORTANT: Connection to the power supply must be effected by means of a fixed power cable which is fitted with a plug-type connection or a two pole isolating switch with a minimum contact opening of 3 mm.

Electrical connection must be carried out by a qualified electrician and in accordance with local regulations and both data on the name-plate and the appropriate diagram inside the terminal box cover.

Follow all safety standards.

8. All electrical work should be carried out in accordance with current IEEE regulations; we recommend the appliance is protected by a Residual Current Device (RCD or Ground-Fault Circuit-Interrupter) with a rated residual operating current not exceeding 30mA.
9. Prior to any modification being made to the equipment, it must be agreed with and authorised by the manufacturer. Original spare parts and accessories authorised by the manufacturer are integral part contributing to the safety of the equipment and of the machines. The use of non original components or accessories may endanger the safety and causes the termination of the warranty. Safe operation is only assured for the applications and conditions described in Application of this manual.

Non-observance of the safety instructions results in the loss of any claims to damages.

The indicated limit values are binding and cannot be exceeded for any reason whatsoever.

KEEP THESE INSTRUCTIONS FOR FUTURE REFERENCE.

Product dimensions

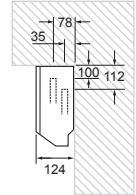
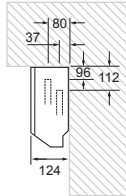
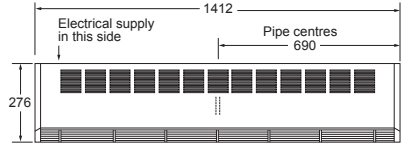
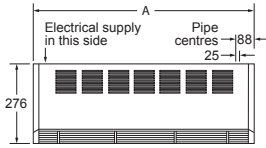

Model	A
1000	470
1000-12V	470
2300	781
2900	1062
4000	1412

Product performance

Heat output

It is recommended that the Ecovector High Level model is capable of maintaining the calculated heat losses at normal heat output (I) enabling the boost settings (II) to be used for faster heat up.

Model	Heat Output at 80°		Heat Output at 75°		Heat Output at 70°	
	Normal (kW)	Boost (kW)	Normal (kW)	Boost (kW)	Normal (kW)	Boost (kW)
ECOVECTOR HL 1000	1.0	1.3	1.0	1.2	0.9	1.1
ECOVECTOR HL 2300	2.3	3.1	2.1	2.8	1.9	2.5
ECOVECTOR HL 2900	2.9	4.2	2.7	4.0	2.5	3.5
ECOVECTOR HL 4000	4.0	5.3	3.7	4.8	3.3	4.4
ECOVECTOR HL 1000-12V	1.0	1.3	1.0	1.2	0.9	1.1

Model	Heat Output at 65°		Heat Output at 60°		Heat Output at 55°	
	Normal (kW)	Boost (kW)	Normal (kW)	Boost (kW)	Normal (kW)	Boost (kW)
ECOVECTOR HL 1000	0.8	1.0	0.7	0.9	0.6	0.8
ECOVECTOR HL 2300	1.7	2.1	1.4	1.9	1.4	1.8
ECOVECTOR HL 2900	2.3	3.2	2.1	2.9	1.9	2.6
ECOVECTOR HL 4000	3.0	4.1	2.7	3.4	2.4	3.2
ECOVECTOR HL 1000-12V	0.8	1.0	0.7	0.9	0.6	0.8

Product performance

Model	Heat Output at 50°		Heat Output at 45°		Heat Output at 40°	
	Normal (kW)	Boost (kW)	Normal (kW)	Boost (kW)	Normal (kW)	Boost (kW)
ECOVECTOR HL 1000	0.5	0.7	0.5	0.6	0.4	0.5
ECOVECTOR HL 2300	1.2	1.6	1.1	1.4	0.9	1.2
ECOVECTOR HL 2900	1.6	2.3	1.4	2.0	1.2	1.7
ECOVECTOR HL 4000	2.1	2.8	1.8	2.5	1.6	2.1
ECOVECTOR HL 1000-12V	0.5	0.7	0.5	0.6	0.4	0.5

Model	Water Capacity (Litres)	Sound Levels		Casting colour	Fan-only
		Normal (dBA)	Boost (dBA)		
ECOVECTOR HL 1000	0.28	32	40	white	•
ECOVECTOR HL 2300	0.32	34	50	white	•
ECOVECTOR HL 2900	0.52	37	51	white	•
ECOVECTOR HL 4000	1.04	39	52	white	•
ECOVECTOR HL 1000-12V	0.28	32	39	white	•

Model	Flow & return connections	Mains cable	Transformer	Fused spur	Total Power Consumption	
					Normal (Watts)	Boost (Watts)
ECOVECTOR HL 1000	15mm	1.5m	n/a	3A	20	25
ECOVECTOR HL 2300	15mm	1.5m	n/a	3A	20	32
ECOVECTOR HL 2900	15mm	1.5m	n/a	3A	33	50
ECOVECTOR HL 4000	22mm	1.5m	n/a	3A	40	60
ECOVECTOR HL 1000-12V	15mm	0.45m	•	3A	20	25

Heat outputs tested in accordance with BS4856 using entering water temperature and 340 l/h (75gph) flow rate. Sound levels measured at 1.5m.

Installation

Please note the guarantee may be invalidated if this product is not installed and used in accordance with this guide.

1. Release the outer casing by removing the screws on the underside of the casing.

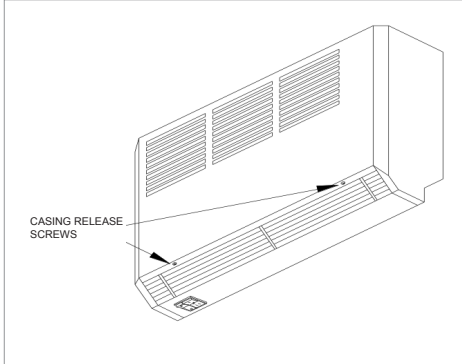

2. Secure heater to the wall using fixings suitable for wall and level. If necessary use packing to compensate for uneven wall surfaces. Maximum recommended installation height is 2.1 metres to the underside of the heater. For models 2900 & 4000 we recommend that two persons should lift the heater into position.

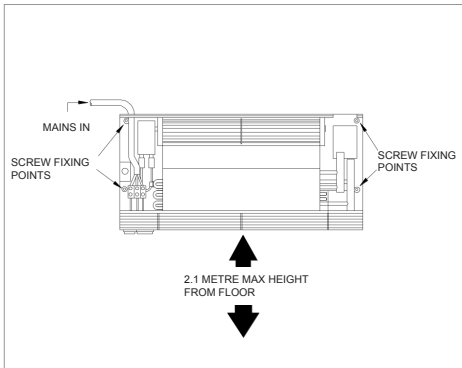

3. Connect the heating system flow and return pipes to the heater pipe work. Do not use soldered fittings to the heater pipe work as the heat generated could damage internal wiring and components. We recommend the use of full low isolating valves. The valves should be accessible after completion of the installation. We also advise the fitting of an air

vent at the highest point on either the flow or the return pipe to remove any air trapped within the system. Check for water leaks. Vent any trapped air from the heating system.

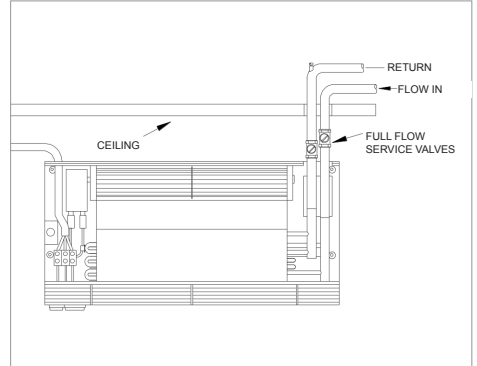

Electrical Connection

Models HL 1000, HL 2300, HL 2900, HL4000

Electrical installations for these heaters must only be carried out by a suitably qualified person. All electrical installation connections must comply with BS7671, 1992 and IEE Regulations. Check the voltage on the heater is correct supply for your supply. If in doubt, consult a qualified electrician.

4. Isolate the electrical supply and connect the heater electric cable to the spur 3A).

The fused spur must not be directly above the heater but should be accessible after the installation is complete.

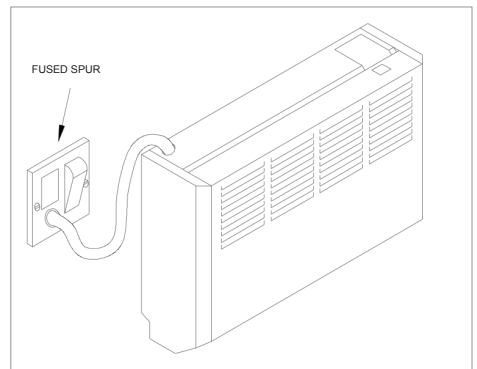

Model HL 1000-12V

This model is designed for use in bathrooms and other high humidity areas. For these applications it is essential that the heater, transformer and fused spur are installed in line with current regulations relative to fixed current equipment in high humidity areas, wet rooms and/or bath and shower rooms. Electrical installations for these heaters must only be carried out by a suitably qualified person. All electrical installations must comply with BS7671, 1992 and IEE Regulations. Check the voltage on the heater is correct for your supply. If in doubt, consult a qualified electrician.

The supplied transformer has been designed to fit into a surface-mounted or recessed pattress box (not supplied) similar to those used for shaver sockets (47mm deep). The transformer can be mounted horizontally or vertically however it must not be directly above the heater but should be accessible after completion of installation.

Supply to the transformer must be via a 3 amp fused spur. The fused spur must not be directly above the heater but should be accessible after completion of the installation. HL 1000-12V should not be earthed.

5. Isolate the electrical supply and connect the mains side of the transformer to the fused spur.
6. Connect between the 12V side of the transformer and the heater using twin core cable fitted to the product.

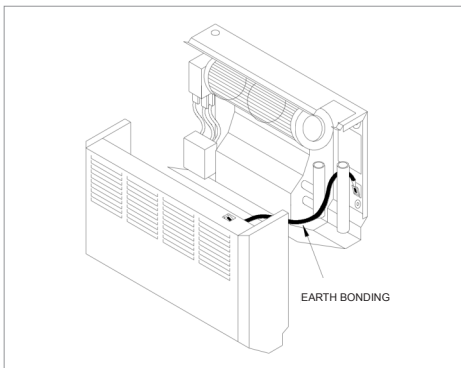

Installation Completion

7. Refit the outer casing to the chassis attaching the earth bonding connector (not model HL 1000-12V) to the outer Casing.

Commissioning

1. Turn on electrical supply at the fused spur.
2. Set the left hand (fan-only) switch to the blue dot and the right hand (heat output) switch to II, the fan should run at boost speed.
3. Turn on the central heating system.
4. Set the room thermostat (if fitted) to maximum.
5. Set the left hand (fan-only) switch to the red dot and the right hand (heat output) switch to I or II – heat will flow within a few minutes.
6. Balance the central heating system if the heater is installed on the same circuit as panel radiators.
7. If the installation is working correctly remember to reset the room thermostat (if fitted) to its normal setting.
8. Please leave this installation & user guide with the property owner for future reference

Fault finding

In the event of any difficulty, please contact us on +44 (0) 1245 324560. It will be helpful if you do not disconnect the heater from the central heating system.

Fault	Checking/Solution
Fan does not run on any switch setting	<p>Check the power supply is switched ON</p> <p>Check the fuse in the fused spur</p> <p>Check the wiring connections at the fused spur</p>
No heat output on settings I or II	<p>Vent any trapped air from the system (with the central heating system turned OFF)</p> <p>Check the central heating is turned ON</p> <p>If fitted ensure the room thermostat is calling for heat</p> <p>Balance the central heating system if installed on the same circuit as panel radiators and increase the circulating pump speed if required</p> <p>Increase the boiler water temperature</p>

User Manual

How an Ecovector fan convector works

Hot water from your central heating system passes through the heat exchanger transferring its heat to the aluminium fins. Cooler air is drawn in by the fan and heated as it passes through the heat exchanger before being Expelled gently back into the room. Fan convectors use around 25% less energy than a radiator to heat up a room, give a more even temperature spread and achieve the required temperature in much less time.

This heater is fitted with a low temperature cut out thermostat that prevents the fan from operating until the central heating system water passing through the heat exchanger reaches 38°.

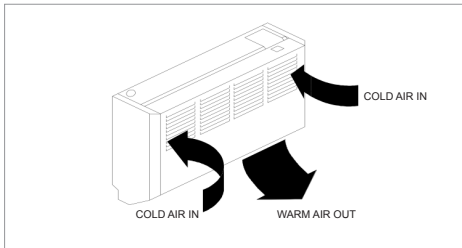

Heating

Ensure your central heating system is on, the heat output switch set to normal I and the fan- only switch set to RED (Heating). Providing the water temperature in the system is more than 38°C and the thermostat/s controlling your central heating system is calling for heat your heater will switch on.

If you require a faster warm up move the heat output switch to boost II. moving the heat output switch to 0 will turn off the heater.

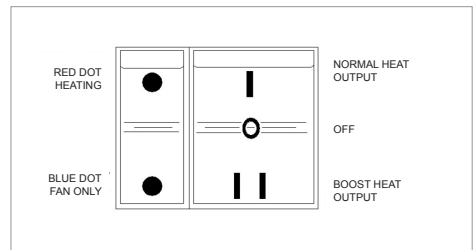

Air Circulation (summer use)

Ensure central heating is off. Set the fan-only switch to BLUE and the heat output switch to either I or II. Ecovector will run to provide a cooling flow of air. If the heater is being used in conjunction with a room thermostat, the thermostat must be set to maximum.

Registering your product

Thank you for purchasing a Smith's product. It has been designed and manufactured to the highest quality standards to ensure it gives you efficient and trouble-free service for many years. We are committed to achieving the highest standards and our faith is supported by a free parts and labour guarantee with every product.

For more information on the warranty period for this product please visit our website smithsep.co.uk/product-registration/

This gives you the peace of mind that in the unlikely event of product failure, we will repair or replace the product completely free of charge providing the product has been installed, used and maintained in accordance with the instructions. Your statutory rights are not affected by this warranty.

It is important to register as soon as possible online at: smithsep.co.uk/product-registration/. This will ensure you will receive prompt and efficient service if your product requires attention within the warranty period. If you do not register your product, you will be required to produce proof of purchase prior to receiving service.

For more details please visit our website: SmithsEP.co.uk

SCAN HERE TO REGISTER
YOUR PRODUCT



Disposal

As part of the policy of continuous product improvement, Smith's Environmental Products LTD reserves the right to alter specification without prior notice.

Products with this symbol (crossed out wheellie bin) cannot be disposed as household waste. Old electrical and electronic equipment must be recycled at a facility capable of handling these products and their waste by-products. If you are purchasing replacement equipment your retailer may offer a 'take back' scheme, or will be able to give details of the nearest approved authorised treatment facility. Proper recycling and waste disposal will help conserve resources whilst preventing detrimental effects on our health and the environment.

WEEE Registered Code: WEE/ED0093VW



Approved CQS ISO
9001:2015



ISO 14001
Certificate No. 202200000

After sales

If you experience any problems with the use of your product, please contact our after-sales office +44 (0) 1245 324560.

For product information, customer services or sales support call us on +44 (0) 1245 324900

For the Republic of Ireland, contact MT Agencies on 01 864 3363

Sales: sales@SmithsEP.co.uk
General information: info@SmithsEP.co.uk

Smith's Environmental Products Ltd
Blackall Industrial Estate, South Woodham Ferrers,
Chelmsford, Essex CM3 5UW

SmithsEP.co.uk

[@SmithsEP_UK](https://twitter.com/SmithsEP_UK)

[#ThinkSmiths](https://www.facebook.com/ThinkSmiths)



Happy to help

Smith's Environmental Products Ltd is one of the leading manufacturers of heating and cooling products in the UK. We are committed to achieving the highest standards and our faith is supported by a free parts and labour guarantee with every product (see our website for more information). Our customer service is second to none and we are happy to offer any help and guidance that you might need.

Stockists

All products are available nationally from Builders' Merchants, Plumbers' Merchants, Heating Equipment Distributors and Kitchen Equipment Distributors. In the event of difficulty, please contact us or visit our website SmithsEP.co.uk for details of your nearest stockist.

Information and advice

Full technical specifications and list prices is available to download from our website or in hard copy from our office. Also available on our website are price lists, individual product data sheets, installation & user guides, where to buy, who to contact and a media centre.

Alternatively contact our office 9.00am to 5.00pm Monday to Friday.

As part our commitment to continuous improvement Smith's Environmental Products may change the specifications of its products without prior notification or public announcement. All descriptions, illustrations, drawings and specifications in this publication present only general particulars and shall not form part of any contract. All dimensions are in mm unless otherwise stated. Please visit the website for the most up to date information.

**To view the full product information
download the datasheet at:
www.SmithsEP.co.uk**

For product information, customer services or sales support call us on **+44 (0) 1245 324900**

For the Republic of Ireland, contact MT Agencies on 01 864 3363

Sales: sales@SmithsEP.co.uk

General information: info@SmithsEP.co.uk

Smith's Environmental Products Ltd
Blackall Industrial Estate, South Woodham Ferrers,
Chelmsford, Essex CM3 5UW

SmithsEP.co.uk

[@SmithsEP_UK](https://twitter.com/SmithsEP_UK)

[#ThinkSmiths](https://www.facebook.com/ThinkSmiths)

Issue 001 | 85-0076 | December 2025